

Novasonar GK 60 / Technical datasheet

Novasonar GK 60 PN



PN version with integrated ML loudspeaker network even operatable with commercially available HiFi equipment.



Novasonar GK flat-panel loudspeakers can be easily integrated in dry mortarless construction (gypsum plaster or gypsum fiber boards).

This flat-panel loudspeaker is suitable for an easy integration in dry mortarless construction. The loudspeaker consists of a commercial gypsum plaster board which is reconstructed to a flat-panel loudspeaker. The model Novasonar GK can be – like a gypsum plaster board – easily into commercial construction of gypsum plaster boards without any effort integrated. A smoothing of the loudspeaker membrane is **not** necessary!

Versions and options

Surface gypsum plaster (12,5mm thickness), different surfaces (e.g. gypsum fiber) on demand

Installation directions

Novasonar GK loudspeakers are mounted like commercial gypsum plaster boards.

A & E Specifications

Description:

Flat-panel loudspeaker for integration in dry mortarless construction.

The loudspeaker system that works on the principle of a bending-wave transducer. It has a flat-panel membrane, which is set into vibration by an exciter that is mounted on the rear.

Easiest, non-visible integration in dry mortarless construction. The loudspeaker consists of a commercial gypsum plaster board, reconstructed to a flat-panel loudspeaker, which can be screwed together with the existing substructure. A smoothing of the loudspeaker membrane is **not** necessary.

The frame has a particularly robust design to reduce the transfer of the membrane vibrations to the surrounding ceiling structure, which could cause the ceiling to rattle. There are no annoying and visible intermediate damping layers. A 100-V transformer and a passive crossover network is also available as an option.

Dimensions:	500 mm x 700 mm x 12,5 (44mm)
Frequency response:	100 Hz – 18000 Hz
Dispersion angle:	180° x 180°
Power handling:	60 watts/ 4 (16) ohms
Sensitivity:	85 dB (1 W / 1m)
Max. SPL:	103 dB (1 m)
Manufacturer:	ML Audio+Carbons
Model:	Novasonar GK 60 (PN)

DIMENSIONS (HxWxD)	500 mm x 700 mm x 44 mm
WEIGHT	4,8 kg
FREQUENCY RESPONSE	100 Hz – 18000 Hz
POWER HANDLING	60 watts RMS (HP 48 dB/oct 150 Hz)
SENSITIVITY	85 dB 1 watt / 1 metre
DISPERSION ANGLE HxV	180° x 180°
IMPEDANCE	4 (16) Ohm
CONNECTION	standard cable
DESIGN	Gypsum plaster

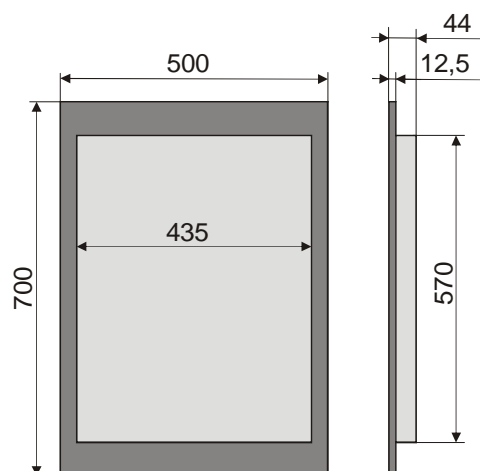

All products subject to technical modification without prior notice. Errors excepted